

# 379 PETERBILT "ULTRA-CAB" DROPPED VISOR

(2002 & UP MODELS)

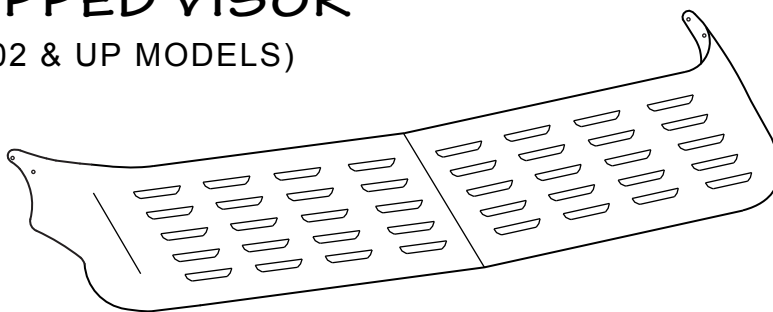
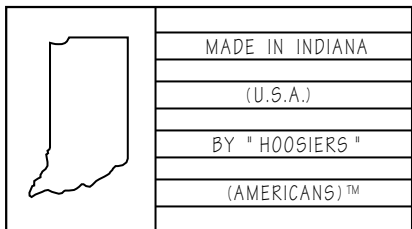

## PARTS REQUIRED FOR THIS INSTALLATION

DRIVERS SIDE  
BRACKETS

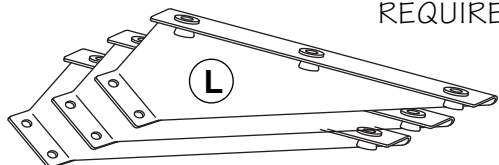

THREE EACH  
REQUIRED

PASS. SIDE  
BRACKETS

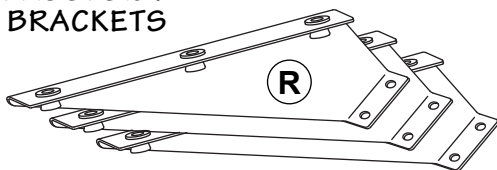

COPYRIGHT © 2007  
RigSkirts LLC.  
ALL RIGHTS RESERVED

### BRACKET ORIENTATION

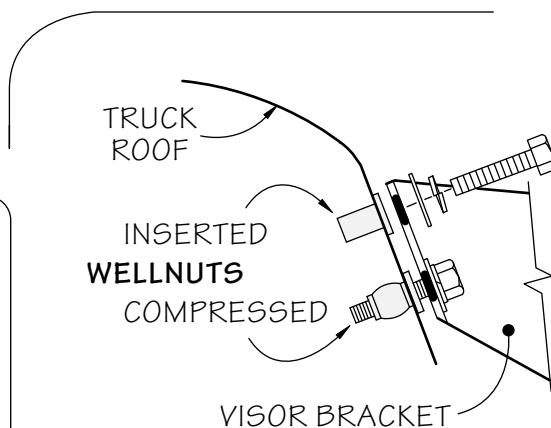
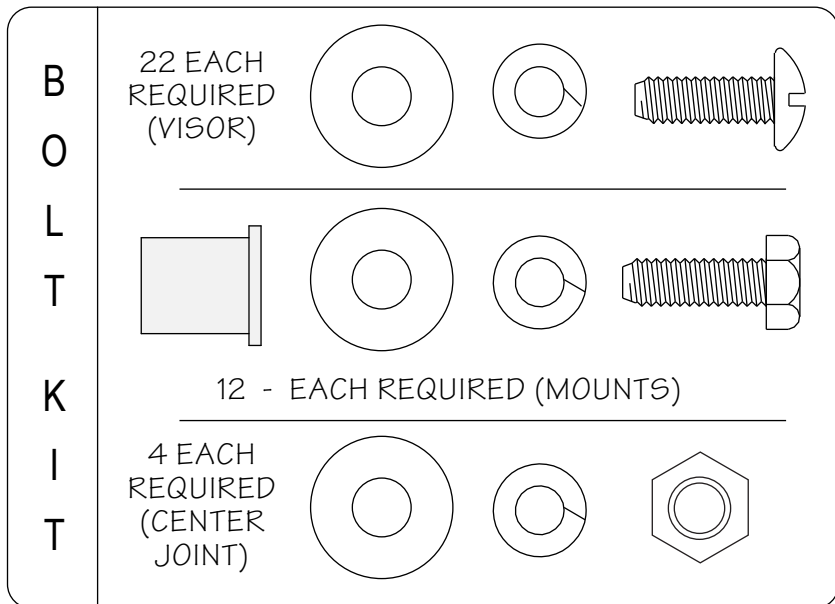
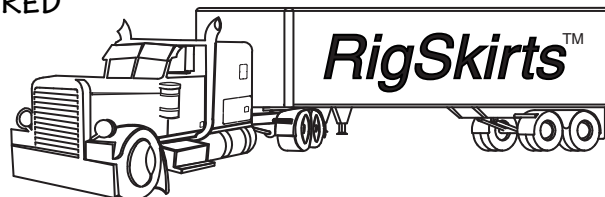
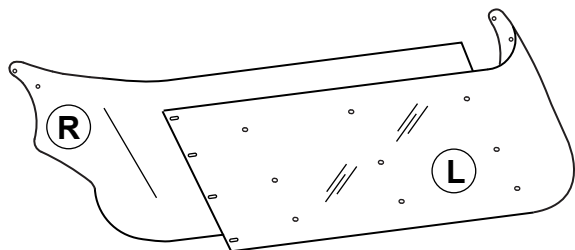

ILLUSTRATION - WELLNUTS



BY

VISOR SECTIONS  
ONE EACH REQUIRED



379 PETERBILT  
"ULTRA-CAB" DROPPED VISOR  
(2002 & UP MODELS)

**INSTRUCTIONS**

1. UNPACK THE CARTON AND DETERMINE THAT ALL PIECES REQUIRED FOR THIS INSTALLATION ARE IN THE BOX. (SEE REVERSE SIDE). PAY PARTICULAR ATTENTION TO THE BOLTS AS THIS INSTALLATION CANNOT BE COMPLETED WITHOUT THE PROPER AMOUNT AND TYPE OF BOLTS AND FASTENERS.  
**NOTE! YOU MUST USE ALL OF THE PARTS SHOWN ON THE REVERSE SIDE OF THIS PAGE OR YOUR WARRANTY BECOMES NULL AND VOID.**
2. REMOVE THE EXISTING SUN VISOR FROM THE TRUCK. SCREW THE BOLTS FROM BOTH ENDS OF THE VISOR TEMPORARILY BACK IN THEIR RESPECTIVE POSITIONS AS WE WILL BE RE-USING THEM.
3. THE NEXT SIX STEPS (#3 THROUGH #8) ARE EXTREMELY IMPORTANT AND REQUIRE THE UTMOST IN CARE AND CAUTION AS WE WILL BE REMOVING THE HUCKBOLTS AND BRACKETS THAT HELD THE OLD SUN VISOR IN PLACE AND INSTALLING THE NEW MOUNTING BRACKETS PROVIDED IN THIS KIT.
4. WITH THE USE OF A SMALL (DO-MOR TYPE) HAND GRINDER, GRIND OFF THE HEADS OF THE HUCKBOLTS THAT SECURE THE VISOR BRACKETS TO THE TRUCK ROOF. **CAUTION:** DO NOT GRIND ON THE HEADS UNTIL THEY OVERHEAT AS THIS COULD DAMAGE THE PAINT AND/OR THE INTERIOR OF TRUCK. THIS IS BEST DONE IN STAGES BY UTILIZING COOL-DOWN PERIODS BETWEEN EACH GRINDING OPERATION.
5. PUSH THE REMAINING PORTION OF THE HUCKBOLTS ON THROUGH THE HOLES IN THE TRUCK ROOF AND REMOVE THE MOUNTING BRACKETS. (THIS REMAINING PORTION OF THE HUCKBOLTS WILL **NOT** BOUNCE AROUND AND/OR RATTLE WHEN LEFT ABOVE THE HEADLINER ON THE INTERIOR OF THE TRUCK).
6. DRILL THE TWELVE MOUNT HOLES ON OUT TO 1/2" (.500") DIAMETER. **NOTE!** IT IS BEST TO USE A DEPTH-STOP OR WRAP A PIECE OF TAPE AROUND THE DRILL BIT TO AVOID PENETRATING DEEPER THAN NECESSARY AND CAUSING DAMAGE TO THE HEADLINER.
7. INSERT THE WELLNUTS INTO THEIR RESPECTIVE HOLES AND PRESS FIRMLY INTO PLACE AS SHOWN IN THE **ILLUSTRATION-WELLNUTS**. (THESE ARE THE RUBBER FASTENERS WITH THE THREADED INSERT INSIDE).
8. MOUNT THE SIX SIDE MOUNTING BRACKETS INTO POSITION AS SHOWN IN THE ILLUSTRATION AND BRACKET ORIENTATION. BE VERY CAREFUL NOT TO OVERTIGHTEN THE BOLTS AS THEY COMPRESS THE NUTSERTS. STOP THE TIGHTENING MOVEMENT AS SOON AS YOU FEEL THE BOLT BOTTOM OUT.
9. PEEL THE P.V.C. PROTECTIVE COATING FROM THE VISOR SECTIONS AND KEEP THEM PROTECTED UNTIL THEY HAVE BEEN COMPLETELY INSTALLED.
10. REMOVE TWO OF THE BOLTS THAT WE TEMPORARILY LEFT IN PLACE (SEE STEP #2) AND LOOSELY BOLT THE END OF THE RIGHT VISOR SECTION TO THE TRUCK. ALSO INSTALL ONE OF THE TRUSS HEAD BOLTS THROUGH THE VISOR AND ON INTO THE BRACKET NEAREST THE CENTER OF THE TRUCK TO TEMPORARILY HOLD IT IN POSITION. REPEAT THIS PROCESS TO INSTALL THE VISOR SECTION ON THE LEFT SIDE.
11. INSTALL THE REST OF THE BOLTS, CHECK THE ENTIRE VISOR FOR PROPER ALIGNMENT AND THEN TIGHTEN ALL OF THE BOLTS. **NOTE!** IT IS A GOOD IDEA TO APPLY A SMALL AMOUNT OF "LOCTITE" TO THE BOLTS WHEN YOU TIGHTEN THEM.
12. USE WINDEX AND A SOFT COTTON CLOTH TO CLEAN THE VISOR AFTER THE INSTALLATION IS COMPLETED. NEVER USE AN ABRASIVE COMPOUND TO CLEAN THE STAINLESS AS IT WILL DAMAGE THE FINISH.
13. AFTER THIS INSTALLATION HAS BEEN COMPLETED, CHECK THE VISOR BOLTS PERIODICALLY TO INSURE THAT THEY HAVE REMAINED TIGHT DURING NORMAL OPERATION OF THE TRUCK.