

FREIGHTLINER "CLASSIC" STANDARD SUN VISOR

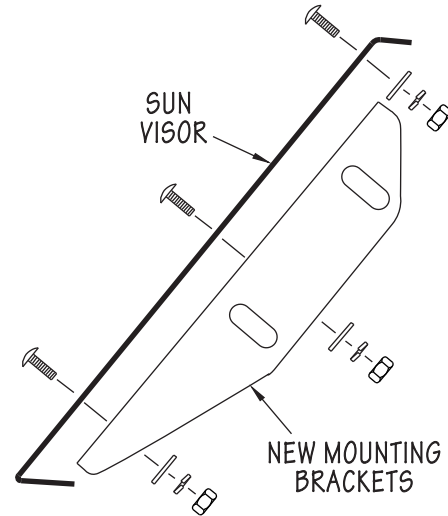
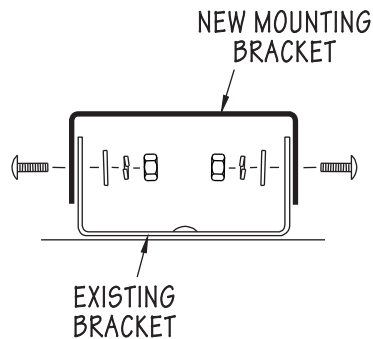
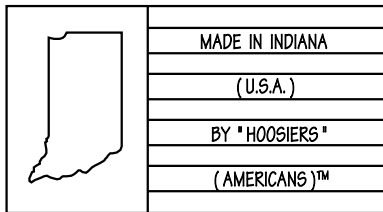
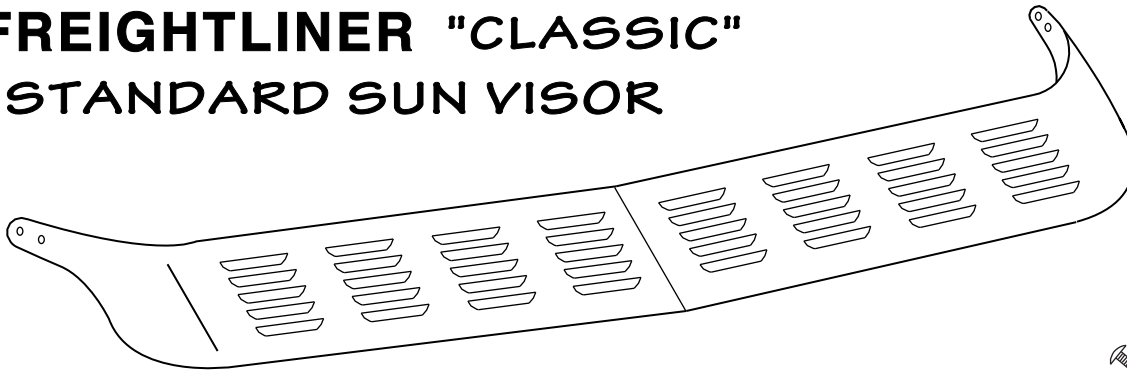

INSTRUCTIONS

ILLUSTRATION

- UNPACK THE CARTON AND DETERMINE THAT ALL PIECES REQUIRED FOR THIS INSTALLATION ARE IN THE BOX. PAY PARTICULAR ATTENTION TO THE BOLTS AS THIS INSTALLATION CANNOT BE COMPLETED WITHOUT THE PROPER AMOUNT AND TYPE OF BOLTS AND FASTENERS.
- REMOVE THE EXISTING SUN VISOR FROM THE TRUCK. ALSO REMOVE THE FOUR EXISTING UPPER MOUNTING BRACKETS.
- BOLT THE FOUR NEW MOUNTING BRACKETS ONTO THE EXISTING ROOF MOUNT BRACKETS AND LEAVE ALL OF THE BOLTS "FINGERTIGHT" UNTIL THIS INSTALLATION HAS BEEN COMPLETED.
- PEEL THE P.V.C. PROTECTIVE COATING FROM THE RIGHT (PASSENGER) SIDE OF THE VISOR. INSERT THE TWO BOLTS IN THE VERY END OF THE OF THE VISOR. PULL THE VISOR SECTION AROUND AND START TWO BOLTS INTO EACH OF THE OUTSIDE BRACKETS TO TEMPORARILY HOLD THIS VISOR SECTION IN PLACE.
- REPEAT STEP #4 TO MOUNT THE LEFT (DRIVERS) SIDE OF THE VISOR.
- INSTALL THE FIVE BOLTS AT THE MID-JOINT.
- INSTALL THE FOUR REMAINING BOLTS INTO THE ROOF BRACKETS. CAREFULLY CHECK THE ENTIRE SUN VISOR FOR PROPER ALIGNMENT,, MAKE A CAREFUL RUN-THROUGH AND TIGHTEN ALL OF THE BOLTS.
NOTE! IT IS A GOOD IDEA TO APPLY A SMALL AMOUNT OF LOCKTITE TO ALL OF THE BOLTS WHEN YOU TIGHTEN THEM.
- USE WINDEX AND A SOFT COTTON CLOTH TO CLEAN THE VISOR AFTER INSTALLATION. NEVER USE AN ABRASIVE COMPOUND ON THE STAINLESS AS IT WILL DAMAGE THE FINISH.
- AFTER THIS INSTALLATION HAS BEEN COMPLETED, CHECK THE VISOR BOLTS PERIODICALLY TO INSURE THAT THEY HAVE REMAINED TIGHT DURING NORMAL OPERATION OF THE TRUCK.



BY

