

"W900 KENWORTH AEROCAB DROPPED VISOR

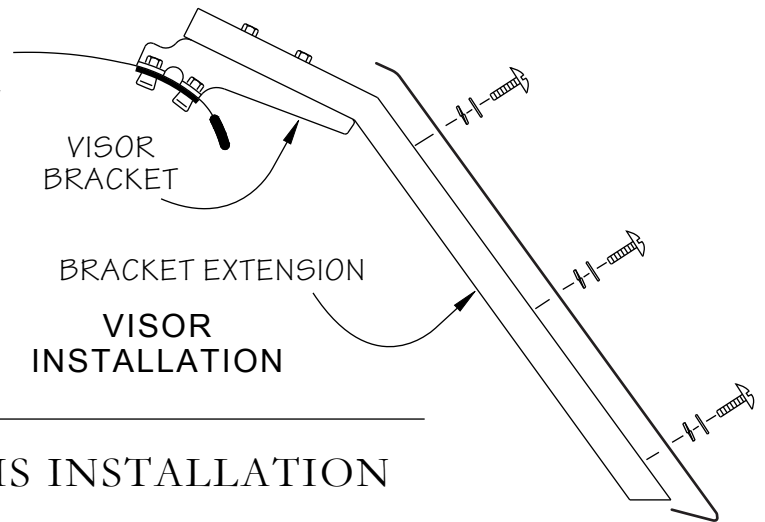
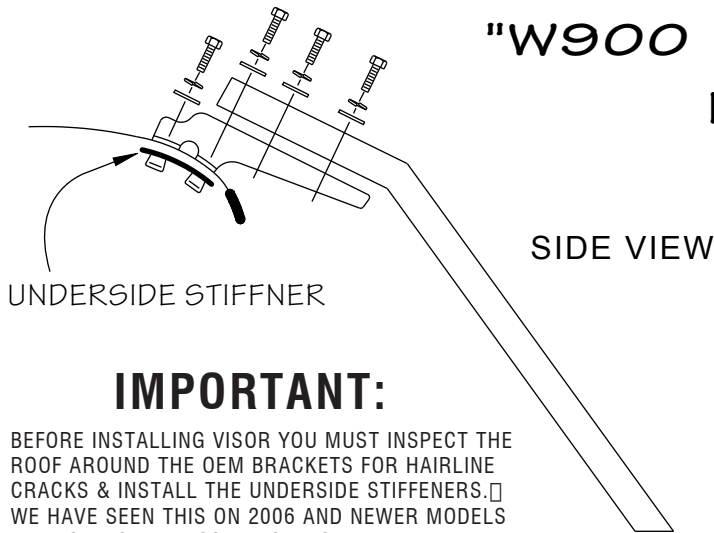

IMPORTANT:

BEFORE INSTALLING VISOR YOU MUST INSPECT THE ROOF AROUND THE OEM BRACKETS FOR HAIRLINE CRACKS & INSTALL THE UNDERSIDE STIFFENERS. □ WE HAVE SEEN THIS ON 2006 AND NEWER MODELS WITH OEM STAINLESS BRACKETS.

PARTS REQUIRED FOR THIS INSTALLATION

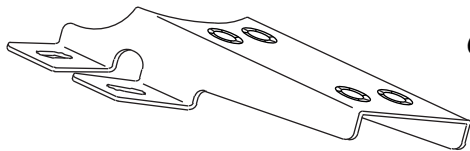

CENTER REPLACEMENT BRACKET
ONE REQUIRED

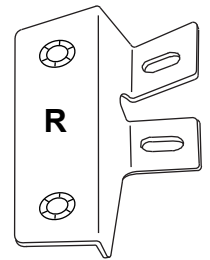
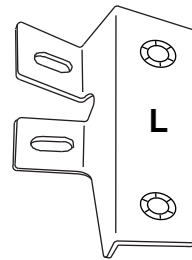

OUTSIDE REPLACEMENT BRACKETS
TWO EACH REQUIRED
(RIGHT & LEFT)

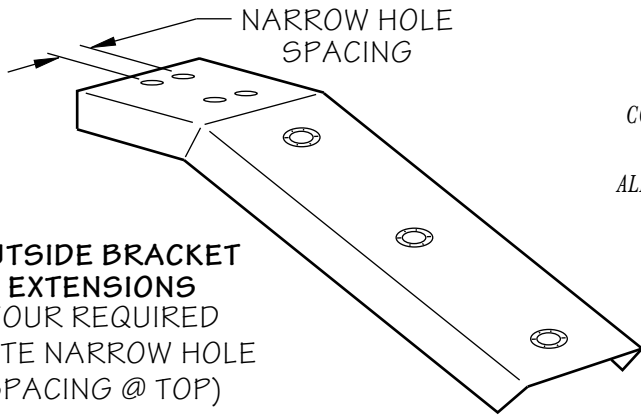

OUTSIDE BRACKET EXTENSIONS
FOUR REQUIRED
(NOTE NARROW HOLE SPACING @ TOP)

COPYRIGHT © 2007
RigSkirts LLC.
ALL RIGHTS RESERVED

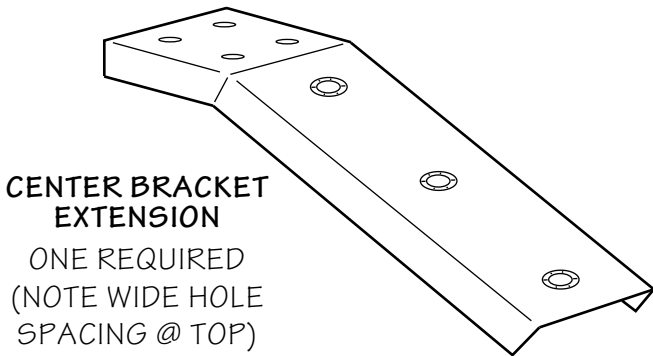

CENTER BRACKET EXTENSION
ONE REQUIRED
(NOTE WIDE HOLE SPACING @ TOP)

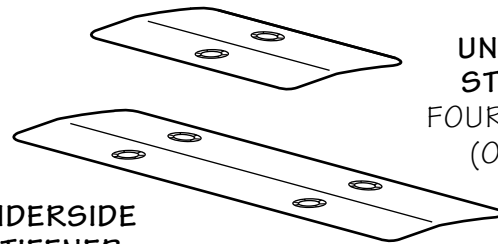

UNDERSIDE STIFFENERS
FOUR REQUIRED
(OUTSIDE)

UNDERSIDE STIFFNER
ONE REQUIRED
(CENTER)

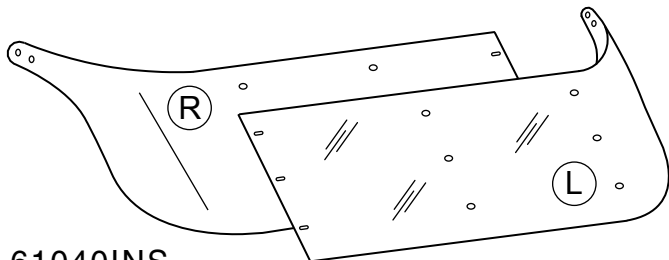

B O L T K I T

- 15 - 1/4" x 3/4" TRUSS HEAD MACHINE SCREWS, WASHERS & LOCKWASHERS
- 12 - 1/4" x 3/4" HEX BOLTS, WASHERS & LOCKWASHERS
- 12 - 1/4" x 1" HEX BOLTS, WASHERS AND LOCKWASHERS

"W900 KENWORTH AEROCAB DROPPED VISOR (WITH CURVED WINDSHIELD)

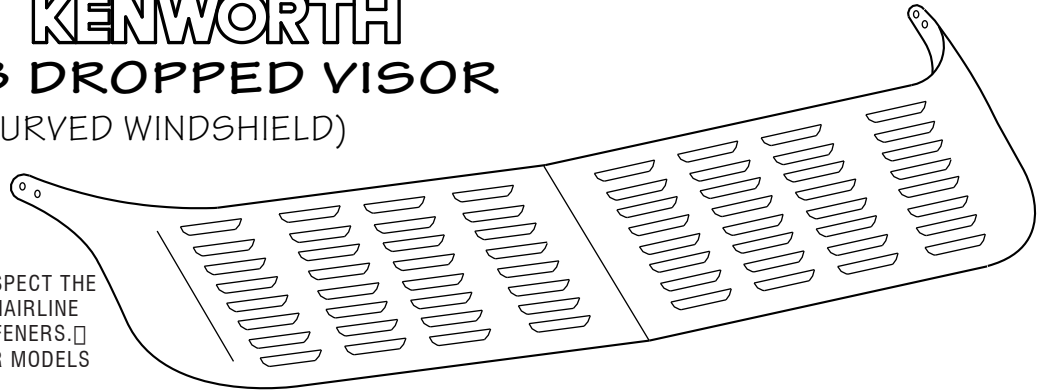

IMPORTANT:

BEFORE INSTALLING VISOR YOU MUST INSPECT THE ROOF AROUND THE OEM BRACKETS FOR HAIRLINE CRACKS & INSTALL THE UNDERSIDE STIFFENERS. □ WE HAVE SEEN THIS ON 2006 AND NEWER MODELS WITH OEM STAINLESS BRACKETS.

INSTRUCTIONS

1. UNPACK THE CARTON AND DETERMINE THAT YOU HAVE RECEIVED ALL OF THE PARTS REQUIRED FOR THIS INSTALLATION (SEE REVERSE SIDE OF THIS PAGE). **NOTE! YOU MUST USE ALL OF THE PARTS SHOWN ON THE REVERSE SIDE OF THIS PAGE OR YOUR WARRANTY BECOMES NULL AND VOID.**
2. REMOVE THE OLD SUN VISOR FROM THE TRUCK AND KEEP THE BOLTS FROM BOTH ENDS OF THE VISOR. REMOVE THE EXISTING MOUNTING BRACKETS FROM THE ROOF OF THE TRUCK.
3. MOUNT THE THREE NEW REPLACEMENT BRACKETS ALONG WITH THE UNDERSIDE STIFFNERS ON THE ROOF WHERE THE OLD BRACKETS WERE MOUNTED. NOTE THAT THE UNDERSIDE STIFFNERS MOUNT **UNDER** THE TRUCK ROOF AND CAN BE ACCESSED THROUGH THE C.B. RADIO CUTOUT OR THROUGH THE SIDE ACCESS PANELS. LEAVE ALL OF THE BOLTS "FINGERTIGHT" UNTIL THIS INSTALLATION HAS BEEN COMPLETED. (SEE ILLUSTRATIONS - REVERSE SIDE OF THIS PAGE).
4. MOUNT THE THREE NEW BRACKET EXTENSIONS SUPPLIED IN THIS KIT ONTO THE NEW VISOR BRACKETS YOU HAVE JUST INSTALLED AND AS SHOWN IN THE SIDE VIEW.
5. MOUNT ONE OF THE REMAINING NEW BRACKETS AND A BRACKET EXTENSION INTO THE **OUTSIDE** ROW OF HOLES ON EACH OF THE TWO VISOR SECTIONS. **CAUTION: DO NOT REMOVE THE PROTECTIVE COATING FROM THE VISOR SECTIONS UNTIL THESE NEW BRACKETS ARE COMPLETELY MOUNTED ON THE TRUCK ROOF.**
6. MOUNT THE TWO VISOR SECTIONS IN PLACE ON THE TRUCK, CHECK FOR PROPER ALIGNMENT AND MARK THE LOCATION OF THE HOLES TO BE DRILLED INTO THE TRUCK ROOF FOR THE TWO NEW MOUNT BRACKETS.
7. REMOVE THE VISOR SECTIONS, DRILL THE 5/16" DIA. HOLES AND MOUNT THESE TWO BRACKETS ALONG WITH THE UNDERSIDE STIFFNERS AND BRACKET EXTENSIONS.
8. PEEL THE P.V.C. PROTECTIVE COATING FROM THE RIGHT (PASSENGER) SIDE VISOR SECTION. PLACE THE VISOR SECTION IN POSITION, INSTALL THE TWO BOLTS IN THE END AND THEN INSTALL THE THREE BOLTS THROUGH THE VISOR AND THE **OUTSIDE** BRACKETS ONLY. LEAVE ALL OF THE REMAINING BOLTS "FINGERTIGHT" UNTIL THIS INSTALLATION HAS BEEN COMPLETED.
9. REPEAT STEP #8 TO MOUNT THE LEFT (DRIVERS) SIDE VISOR SECTION.
10. INSTALL THE THREE BOLTS THROUGH BOTH VISOR SECTIONS AND INTO THE CENTER MOUNTING BRACKET WHERE THE TWO VISOR SECTIONS JOIN. CHECK FOR PROPER ALIGNMENT AND TIGHTEN ALL BOLTS. **NOTE! IT IS A GOOD IDEA TO APPLY A SMALL AMOUNT OF LOCTITE TO ALL OF THE BOLTS WHEN YOU TIGHTEN THEM.**
11. USE WINDEX AND A SOFT COTTON CLOTH TO CLEAN THE VISOR AFTER INSTALLATION. NEVER USE AN ABRASIVE COMPOUND ON THE STAINLESS AS IT WILL DAMAGE THE FINISH.
12. AFTER THIS INSTALLATION HAS BEEN COMPLETED, CHECK THE VISOR BOLTS PERIODICALLY TO INSURE THAT THEY HAVE REMAINED TIGHT DURING NORMAL OPERATION OF THE TRUCK.

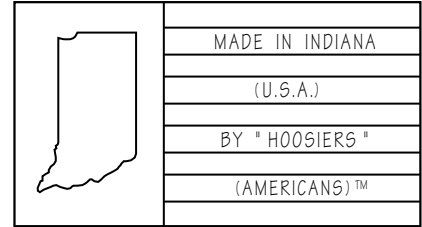

BY

