

FREIGHTLINER DROPPED VISOR

(MODELS WITH FACTORY STAINLESS VISOR)

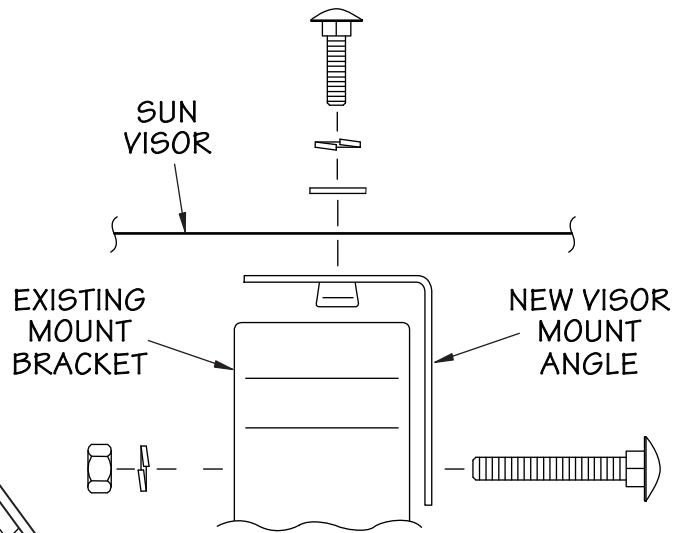
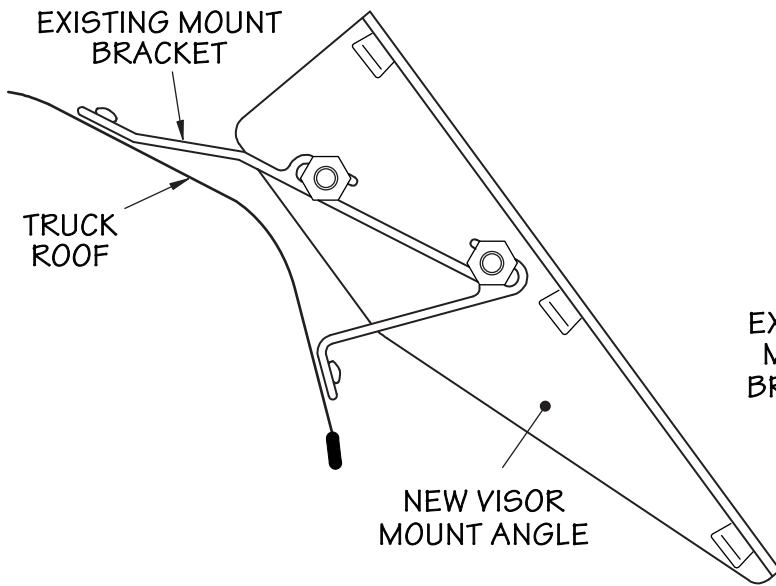

FRONT VIEW

ROOF MOUNTING ILLUSTRATION
DRIVERS SIDE SHOWN

PARTS REQUIRED FOR THIS INSTALLATION

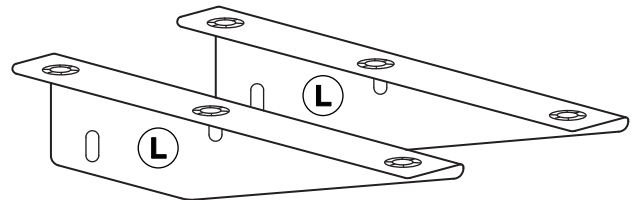
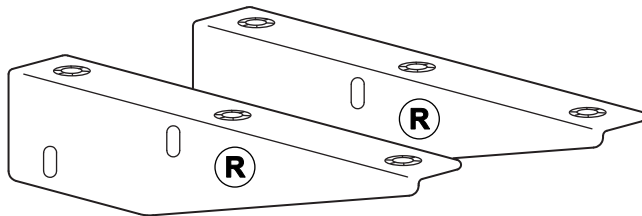

VISOR MOUNT ANGLES
TWO REQUIRED EACH
(RIGHT - LEFT)

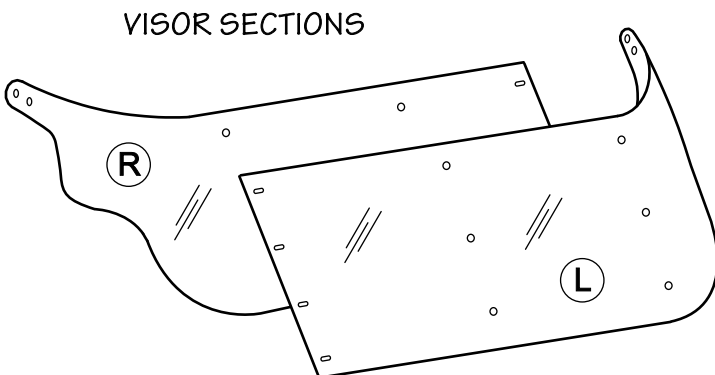

BOLT KIT

- 13 - 1/4" x 3/4" TRUSS HEAD MACHINE SCREWS, WASHERS & LOCKWASHERS
- 9 - 1/4" x 3/4" HEX BOLTS, WASHERS & LOCKWASHERS
- 9 - 1/4" x 2 1/4" C.B., NUTS & L.W.
- 5 - 3/16" x 1/2" S.S. C.B., NUTS & EXT. L.W.
- 10 - 1/4" S.S. FLAT WASHERS

FREIGHTLINER DROPPED VISOR

(MODELS WITH FACTORY STAINLESS VISOR)

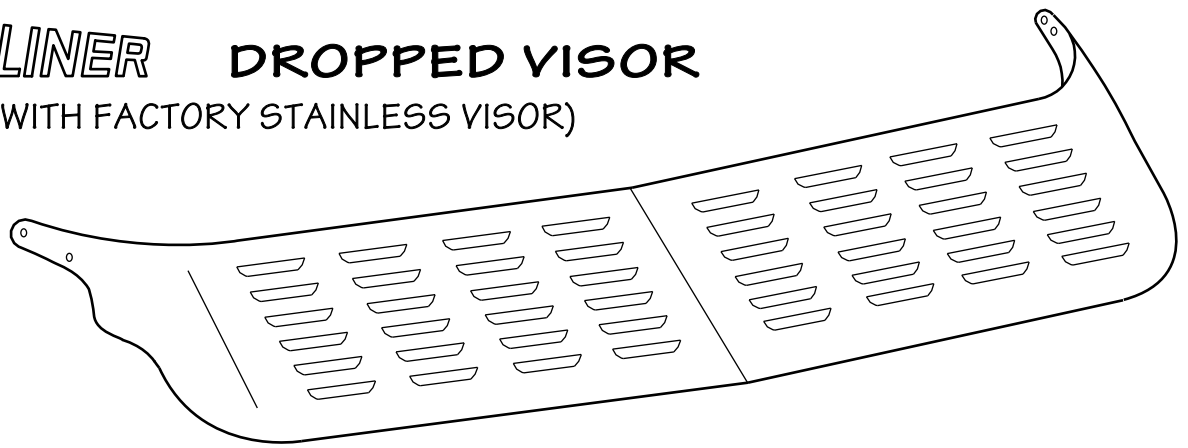

INSTRUCTIONS

1. UNPACK THE CARTON AND DETERMINE THAT YOU HAVE RECEIVED ALL OF THE PARTS REQUIRED FOR THIS INSTALLATION. SEE REVERSE SIDE OF THIS PAGE FOR BOLT AND PARTS LISTING.
NOTE! YOU MUST USE ALL OF THE PARTS SHOWN ON THE REVERSE SIDE OF THIS PAGE OR YOUR WARRANTY BECOMES NULL AND VOID.
2. REMOVE THE OLD SUN VISOR FROM THE TRUCK AND KEEP THE BOLTS FROM BOTH ENDS OF THE VISOR.
3. MOUNT THE FOUR NEW VISOR MOUNTING ANGLES ONTO THE EXISTING ROOF MOUNT BRACKETS AS SHOWN IN THE "ROOF MOUNTING INSTALLATION". KEEP ALL OF THE BOLTS "FINGERTIGHT" UNTIL THIS INSTALLATION HAS BEEN COMPLETED.
4. PEEL THE P.V.C. PROTECTIVE COATING FROM THE RIGHT (PASSENGER) SIDE OF THE VISOR. INSERT THE TWO BOLTS IN THE VERY END OF THE VISOR SECTION, PUSH THE VISOR DOWN AGAINST THE BRACKETS AND START THE BOLTS INTO THE OUTSIDE BRACKETS.
5. REPEAT STEP #4 TO MOUNT THE LEFT (DRIVERS) SIDE OF THE VISOR. POSITION THE TWO VISOR SECTIONS AND INSTALL THE BOLTS AT THE CENTER JOINT. NOTE THAT THE VISOR SECTION ON THE DRIVERS SIDE OVERLAPS THE PASSENGER SIDE.
6. CHECK THE COMPLETED SUN VISOR FOR PROPER ALIGNMENT AND TIGHTEN ALL OF THE BOLTS. **NOTE!** IT IS A GOOD IDEA TO APPLY A SMALL AMOUNT OF LOCKTITE TO ALL OF THE BOLTS WHEN YOU TIGHTEN THEM.
7. USE WINDEX AND A SOFT COTTON CLOTH TO CLEAN THE VISOR AFTER INSTALLATION. NEVER USE AN ABRASIVE COMPOUND ON THE STAINLESS AS IT WILL DAMAGE THE FINISH.
8. AFTER THIS INSTALLATION HAS BEEN COMPLETED, CHECK THE VISOR BOLTS PERIODICALLY TO INSURE THAT THEY HAVE REMAINED TIGHT DURING NORMAL OPERATION OF THE TRUCK.

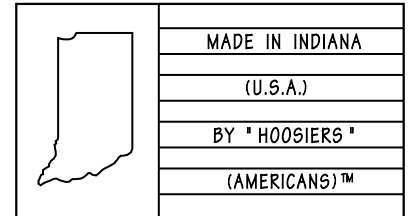

BY

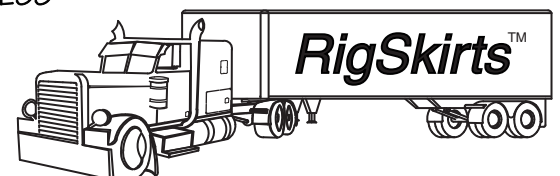

COPYRIGHT © 2007
RigSkirts LLC.
ALL RIGHTS RESERVED