

FREIGHTLINER "CONDO" SUN VISOR

PARTS LIST

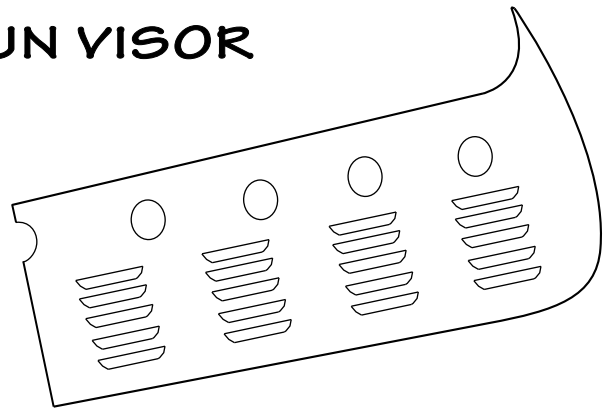
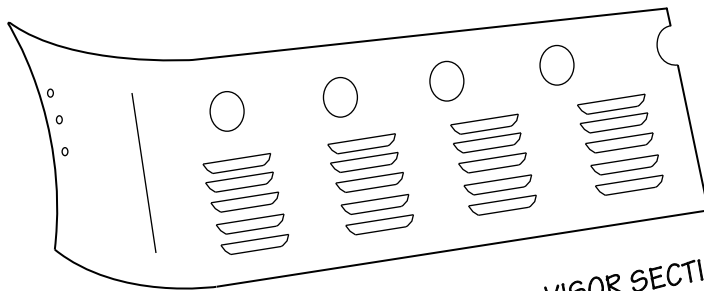

VISOR SECTIONS (2)

COPYRIGHT © 2007
RigSkirts LLC.
ALL RIGHTS RESERVED

COMPLETE BOLT PACKAGE

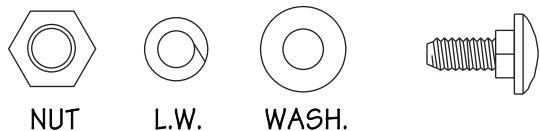
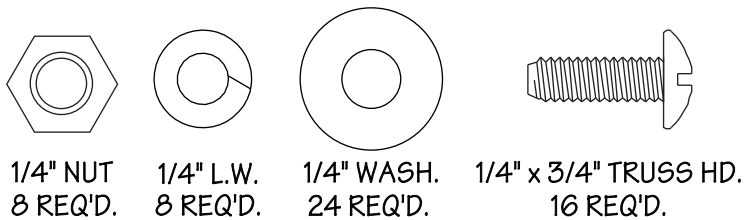

3/16" x 1/2" CARRIAGE BOLT NUT, WASH. & L.W.
4 EACH REQUIRED

BRACES

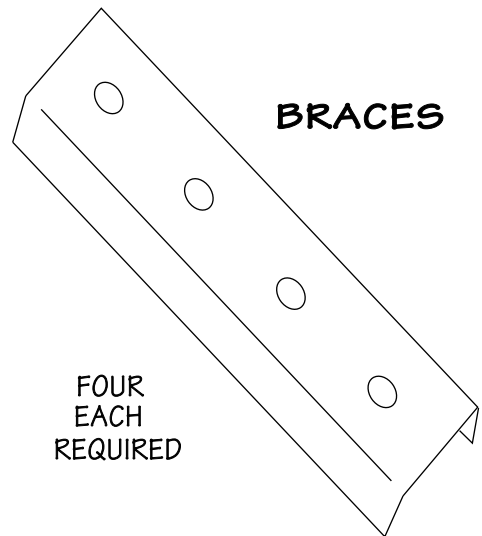

FOUR
EACH
REQUIRED

LIGHTING KIT

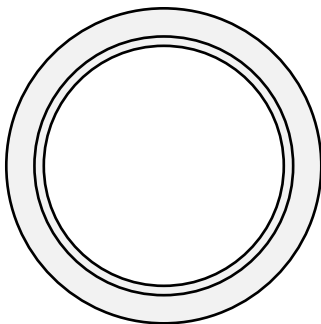

2" RUBBER GROMMET
9 EACH REQUIRED

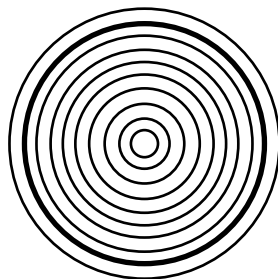

2" ROUND LIGHTS
9 EACH REQUIRED



WIRE HARNESS - 1 REQUIRED



BY

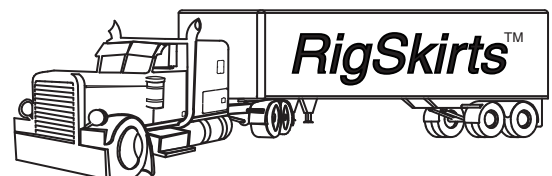

FREIGHTLINER "CONDO" SUN VISOR

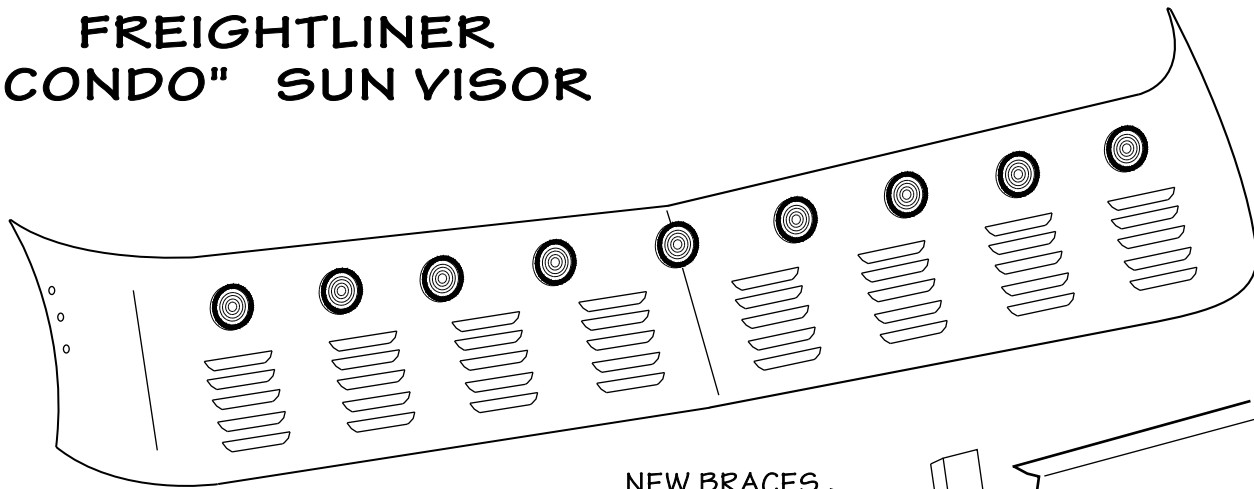

	MADE IN INDIANA
	(U.S.A.)
	BY "HOOSIERS"
	(AMERICANS)™

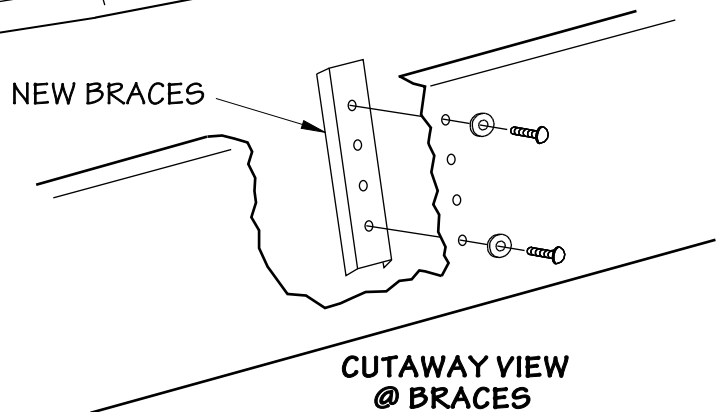

INSTRUCTIONS

1. UNPACK THE CARTON AND DETERMINE THAT ALL PIECES REQUIRED FOR THIS INSTALLATION ARE IN THE BOX. (SEE REVERSE SIDE). PAY PARTICULAR ATTENTION TO THE BOLTS AS THIS INSTALLATION CANNOT BE COMPLETED WITHOUT THE PROPER AMOUNT AND TYPE OF BOLTS AND FASTENERS.
2. REMOVE THE OLD SUN VISOR FROM THE TRUCK AND LOOSEN THE EXISTING BOLTS IN EACH OF THE BRACKETS AS THEY WILL HAVE TO BE RE-POSITIONED. (THREE BOLTS PER BRACKET). KEEP THE SIX BOLTS FROM THE ENDS OF THE VISOR IN A CONTAINER AS WE WILL RE-USE THEM FOR INSTALLING THE NEW VISOR.
3. MOUNT THE FOUR NEW BRACES ONTO THE BACK SIDE OF THE VISOR HALVES UTILIZING ONLY THE TOP AND BOTTOM BOLTS AS SHOWN IN THE CUTAWAY VIEW. APPLY A MEASURED AMOUNT OF LOCKTITE AND TIGHTEN THESE EIGHT BOLTS.
4. MOUNT THE RIGHT SIDE OF THE VISOR ONTO THE PASSENGER SIDE OF THE TRUCK. USE ONLY THE THREE BOLTS IN THE END OF THE VISOR AND ONE BOLT IN EACH OF THE ROOF BRACKETS. LEAVE ALL OF THE BOLTS IN A "FINGERTIGHT" CONDITION UNTIL THE VISOR INSTALLATION HAS BEEN COMPLETED.
5. REPEAT STEP #4 TO INSTALL THE VISOR ON THE DRIVERS SIDE OF THE TRUCK (LEFT).
6. INSTALL THE FOUR BOLTS AT THE MID-JOINT AND TIGHTEN. **NOTE!** IT IS A GOOD IDEA TO APPLY A SMALL AMOUNT OF LOCKTITE TO ALL OF THE REMAINING BOLTS WHEN YOU TIGHTEN THEM.
7. INSTALL THE FOUR REMAINING BOLTS INTO THE ROOF BRACKETS. CAREFULLY CHECK THE ENTIRE SUN VISOR FOR PROPER ALIGNMENT. MAKE A CAREFUL RUN-THROUGH AND TIGHTEN ALL OF THE BOLTS.
8. YOU ARE NOW READY TO INSTALL AND WIRE THE LIGHTS.
9. AFTER THE INSTALLATION IS COMPLETED AND DURING THE NORMAL OPERATION OF THE TRUCK, IT IS A GOOD IDEA TO CHECK THE VISOR BOLTS PERIODICALLY TO INSURE THAT THEY REMAIN TIGHT.