

FREIGHTLINER "CENTURY" DROPPED SUN VISOR

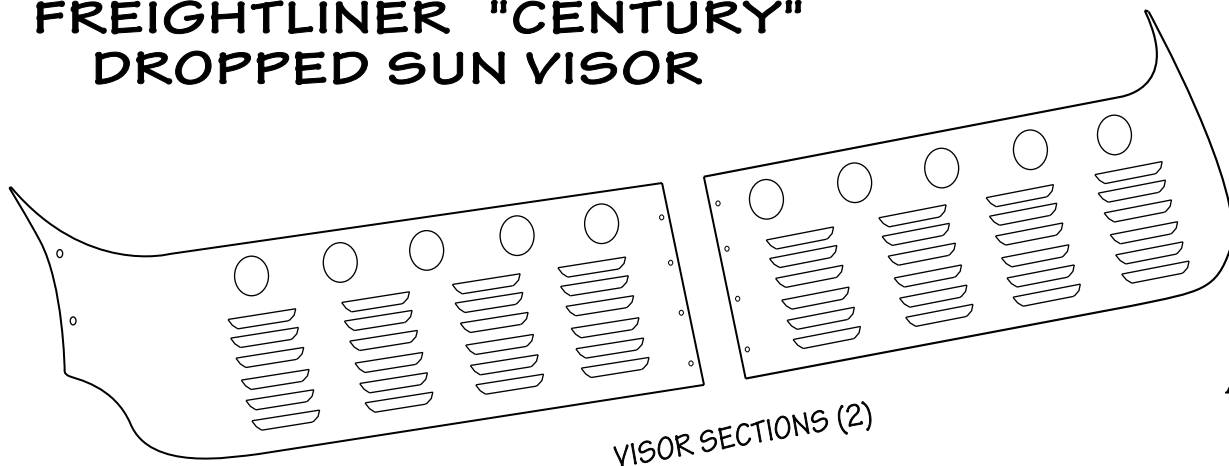

VISOR SECTIONS (2)

COPYRIGHT © 2007
RigSkirts LLC.
ALL RIGHTS RESERVED

BOLT PACKAGE

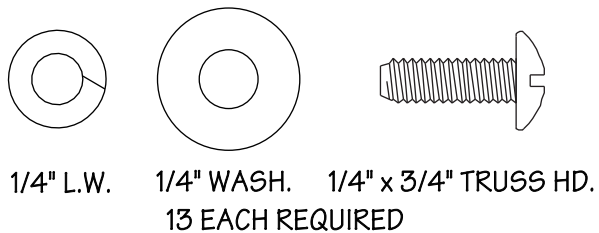

1/4" L.W. 1/4" WASH. 1/4" x 3/4" TRUSS HD.
13 EACH REQUIRED

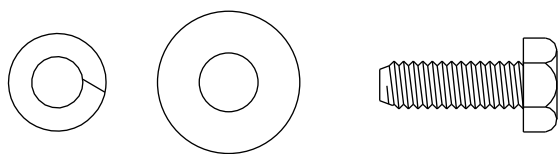

1/4" x 1" HEX BOLT, WASH. & L.W.
7 EACH REQUIRED

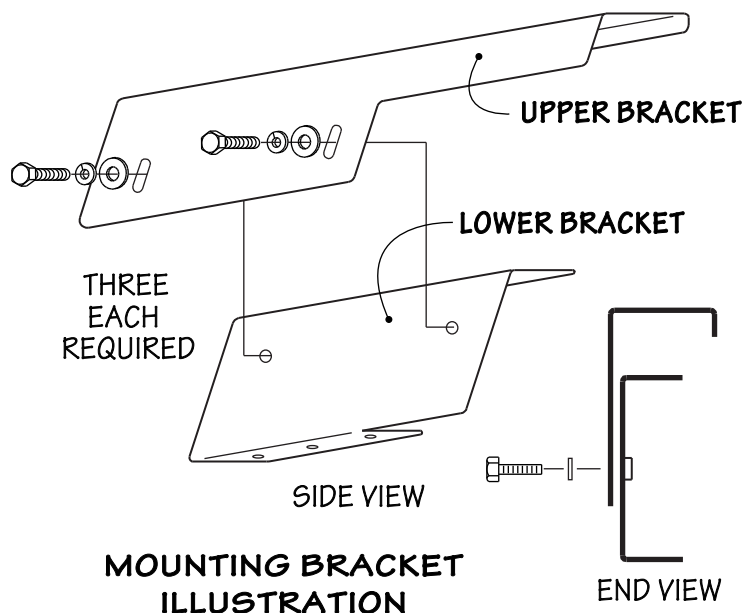

MOUNTING BRACKET
ILLUSTRATION

LIGHTING KIT

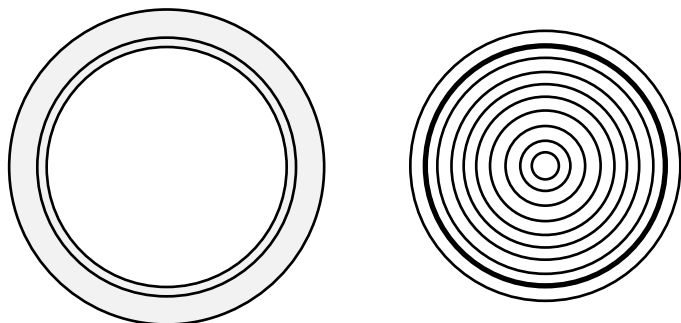

2" RUBBER GROMMET
10 EACH REQUIRED

2" ROUND LIGHTS
10 EACH REQUIRED



WIRE HARNESS - 1 REQUIRED



BY

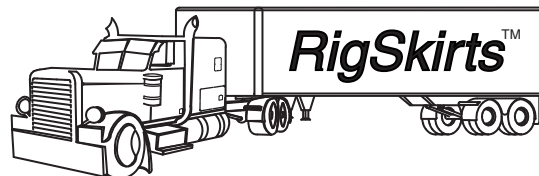

FREIGHTLINER "CENTURY" DROPPED SUN VISOR

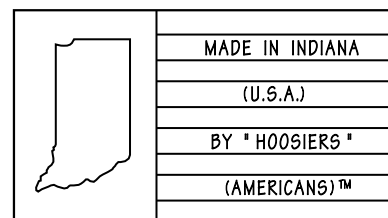
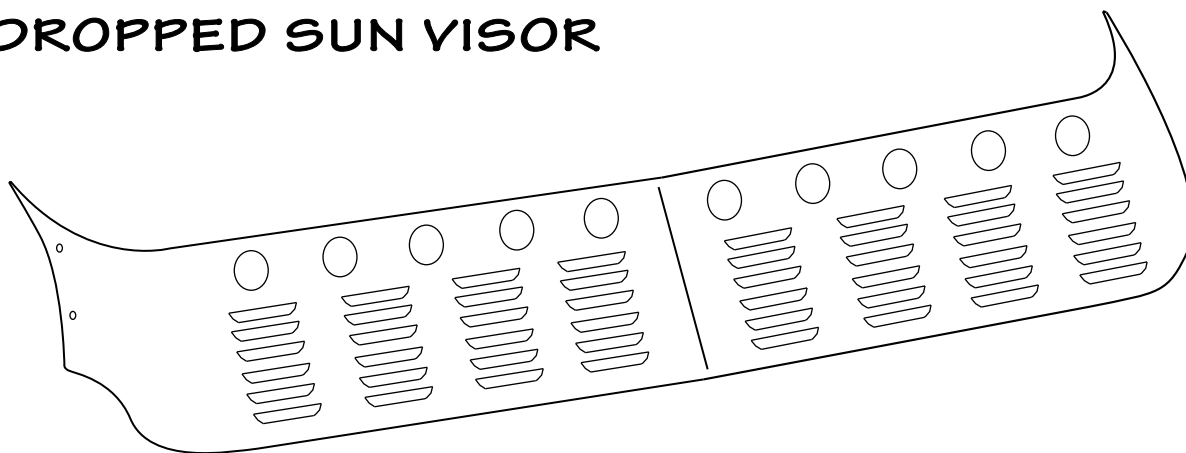

INSTRUCTIONS

1. UNPACK THE CARTON AND DETERMINE THAT ALL PIECES REQUIRED FOR THIS INSTALLATION ARE IN THE BOX. (SEE REVERSE SIDE). PAY PARTICULAR ATTENTION TO THE BOLTS AS THIS INSTALLATION CANNOT BE COMPLETED WITHOUT THE PROPER AMOUNT AND TYPE OF BOLTS AND FASTENERS.
2. REMOVE THE EXISTING SUN VISOR AND ALL OF THE MOUNTING BRACKETS. KEEP ALL OF THE BOLTS IN A CONTAINER AS WE WILL BE RE-USING THEM TO INSTALL THE NEW SUN VISOR.
3. INSTALL THE THREE NEW **LOWER** MOUNTING BRACKETS ONTO THE TRUCK ROOF UTILIZING THE BOLTS THAT HELD THE OLD BRACKETS IN PLACE. TIGHTEN THESE SIX BOLTS ONLY.
4. BOLT THE **UPPER** MOUNTING BRACKETS TO THE LOWER BRACKETS YOU HAVE JUST INSTALLED (SEE ILLUSTRATION FOR PROPER ORIENTATION). LEAVE THESE AND ALL THE REST OF THE BOLTS "FINGERTIGHT" UNTIL THIS INSTALLATION HAS BEEN COMPLETED.
5. MOUNT THE RIGHT SIDE OF THE VISOR ONTO THE PASSENGER SIDE OF THE TRUCK. USE ONLY THE TWO BOLTS IN THE END OF THE VISOR AND ONE BOLT IN THE OUTSIDE ROOF BRACKET.
6. REPEAT STEP #4 TO INSTALL THE VISOR ON THE DRIVERS SIDE OF THE TRUCK (LEFT).
7. INSTALL THE FOUR BOLTS AT THE MID-JOINT, THE REMAINING SIX BOLTS IN THE OUTSIDE BRACKETS, CHECK THE VISOR FOR PROPER ALIGNMENT AND TIGHTEN ALL OF THESE BOLTS.
NOTE! IT IS A GOOD IDEA TO APPLY A SMALL AMOUNT OF LOCKTITE TO ALL OF THE BOLTS WHEN YOU TIGHTEN THEM.
8. TIGHTEN ALL OF THE BOLTS THAT JOIN THE MOUNTING BRACKETS ON THE UNDER SIDE OF THE VISOR. TIGHTEN THE FOUR BOLTS IN THE ENDS OF THE VISOR AND MAKE SURE THAT ALL OF THE BOLTS HAVE NOW BEEN TIGHTENED.
9. YOU ARE NOW READY TO INSTALL AND WIRE THE LIGHTS.
10. AFTER THE INSTALLATION IS COMPLETED AND DURING THE NORMAL OPERATION OF THE TRUCK, IT IS A GOOD IDEA TO CHECK THE VISOR BOLTS PERIODICALLY TO INSURE THAT THEY REMAIN TIGHT.