

FREIGHTLINER "MID-ROOF" SUN VISOR

PARTS REQUIRED FOR THIS INSTALLATION

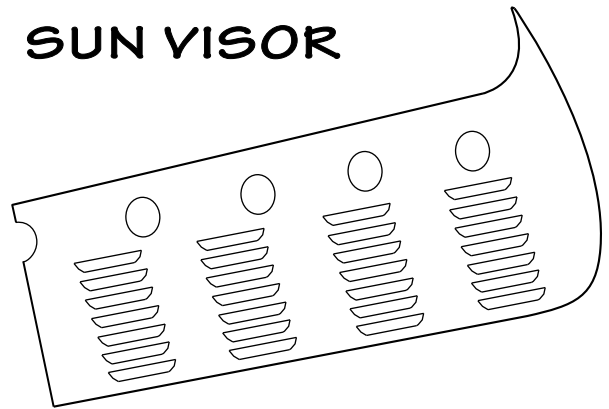
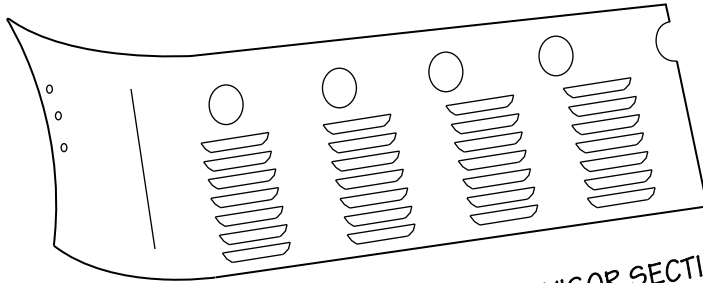

VISOR SECTIONS (2)

COPYRIGHT © 2007
RigSkirts LLC.
ALL RIGHTS RESERVED

COMPLETE BOLT PACKAGE

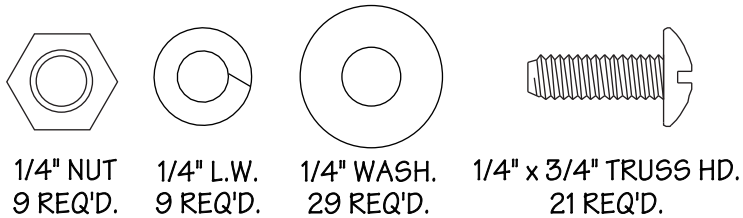

1/4" NUT 9 REQ'D. 1/4" L.W. 9 REQ'D. 1/4" WASH. 29 REQ'D. 1/4" x 3/4" TRUSS HD. 21 REQ'D.

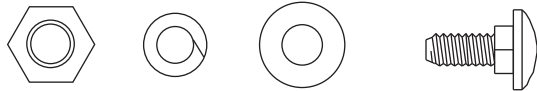

NUT L.W. WASH.
3/16" x 1/2" CARRIAGE BOLT NUT, WASH. & L.W.
5 EACH REQUIRED

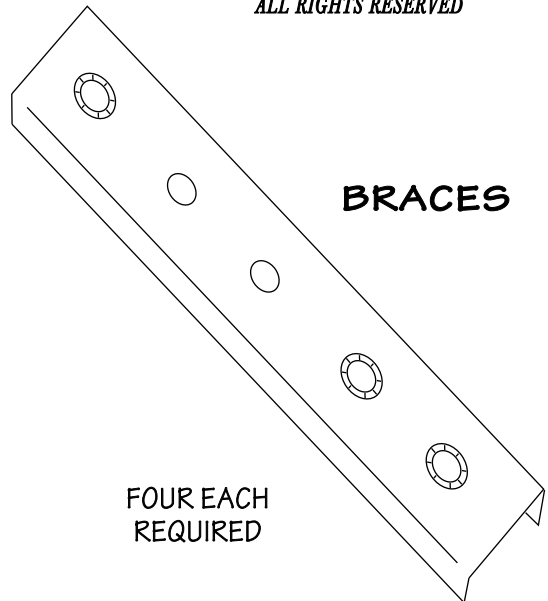

BRACES

FOUR EACH
REQUIRED

LIGHTING KIT

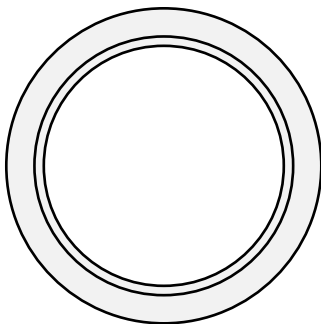

2" RUBBER GROMMET
9 EACH REQUIRED

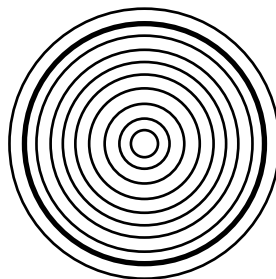

2" ROUND LIGHTS
9 EACH REQUIRED



WIRE HARNESS - 1 REQUIRED



BY



FREIGHTLINER "MID-ROOF" SUN VISOR

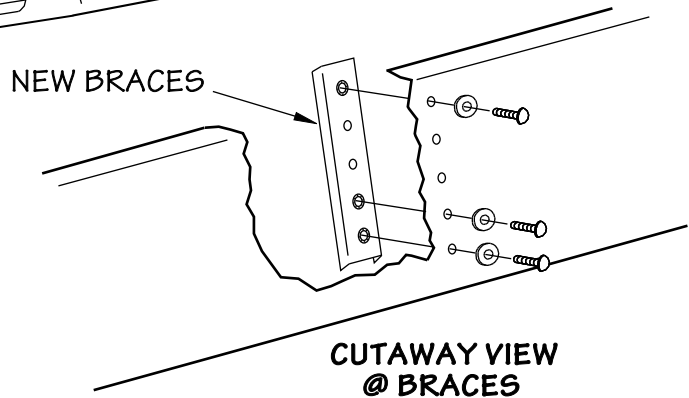
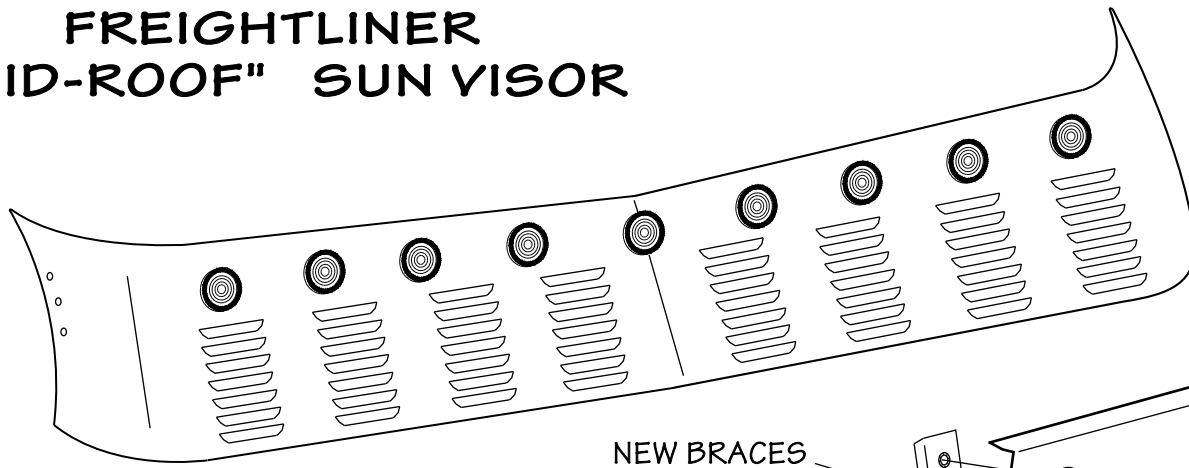

	MADE IN INDIANA
	(U.S.A.)
	BY "HOOSIERS"
	(AMERICANS)™

INSTRUCTIONS

1. UNPACK THE CARTON AND DETERMINE THAT YOU HAVE RECEIVED ALL OF THE PARTS REQUIRED FOR THIS INSTALLATION. SEE REVERSE SIDE OF THIS PAGE FOR BOLT KIT AND PARTS LISTING. **NOTE! YOU MUST USE ALL OF THE PARTS SHOWN ON THE REVERSE SIDE OF THIS PAGE OR YOUR WARRANTY BECOMES NULL AND VOID.**
2. REMOVE THE OLD SUN VISOR FROM THE TRUCK ROOF AND KEEP THE SIX BOLTS FROM THE ENDS OF THE VISOR IN A CONTAINER AS WE WILL RE-USE THEM FOR INSTALLING THE NEW VISOR.
3. LOOSEN THE BOLTS ON EACH OF THE ROOF MOUNTING BRACKETS AS THEY WILL HAVE TO BE RE-POSITIONED WHEN THE NEW VISOR IS INSTALLED (THREE BOLTS PER BRACKET).
4. MOUNT THE FOUR NEW BRACES ONTO THE BACK SIDE OF THE VISOR HALVES UTILIZING ONLY THE TOP AND **TWO** BOTTOM BOLTS AS SHOWN IN THE CUTAWAY VIEW ABOVE.
5. MOUNT THE RIGHT SIDE OF THE VISOR ONTO THE PASSENGER SIDE OF THE TRUCK. USE ONLY THE THREE BOLTS IN THE END OF THE VISOR AND ONE BOLT IN EACH OF THE ROOF BRACKETS. LEAVE ALL OF THE BOLTS IN A "FINGERTIGHT" CONDITION UNTIL THE VISOR INSTALLATION HAS BEEN COMPLETED.
6. REPEAT STEP #4 TO INSTALL THE VISOR ON THE DRIVERS SIDE OF THE TRUCK (LEFT).
7. INSTALL THE FOUR SMALL CARRIAGE BOLTS AT THE MID-JOINT AND TIGHTEN. **NOTE!** IT IS A GOOD IDEA TO APPLY A SMALL AMOUNT OF LOCKTITE TO THESE AND ALL OF THE REMAINING BOLTS WHEN YOU TIGHTEN THEM.
8. INSTALL THE FOUR REMAINING BOLTS INTO THE ROOF BRACKETS. CAREFULLY CHECK THE ENTIRE SUN VISOR FOR PROPER FIT AND ALIGNMENT. MAKE A CAREFUL RUN-THROUGH AND TIGHTEN ALL OF THE NEW VISOR BOLTS - THEN TIGHTEN THE BOLTS IN THE OLD ROOF MOUNT BRACKETS.
9. YOU ARE NOW READY TO INSTALL AND WIRE THE LIGHTS.
10. USE WINDEX AND A SOFT COTTON CLOTH TO CLEAN THE VISOR AFTER INSTALLATION. CAUTION: NEVER USE AN ABRASIVE COMPOUND ON THE STAINLESS AS IT WILL DAMAGE THE FINISH.
11. AFTER THE INSTALLATION IS COMPLETE AND DURING THE NORMAL OPERATION OF THE TRUCK, IT IS A GOOD IDEA TO CHECK THE VISOR BOLTS PERIODICALLY TO INSURE THAT THEY REMAIN TIGHT.